

Cumulative Levels and Effects Analysis for Air Permitting in Minneapolis

Sarah Sevcik

Air Permit Engineer



**Minnesota Pollution
Control Agency**

A Little Background



Excerpt from Minn. Stat. § 116.07, subd. 4a

The agency may not issue a permit to a facility without **analyzing and considering the cumulative levels and effects of past and current environmental pollution from all sources on the environment and residents of the geographic area within which the facility's emissions are likely to be deposited,**

provided that the facility is located in a community in a city of the first class in Hennepin County that meets all of the following conditions:

- (1) is within a half mile of a site designated by the federal government as an EPA superfund site due to residential arsenic contamination;
- (2) a majority of the population are low-income persons of color and American Indians;
- (3) a disproportionate percent of the children have childhood lead poisoning, asthma, or other environmentally related health problems;
- (4) is located in a city that has experienced numerous air quality alert days of dangerous air quality for sensitive populations between February 2007 and February 2008; and
- (5) is located near the junctions of several heavily trafficked state and county highways and two one-way streets which carry both truck and auto traffic.



Process Document to Comply with Minn. Stat. § 116.07 subd. 4a

Reference Document for Minnesota Statute § 116.07, Subdivision 4a

Information source for use in complying with statute





Minnesota Pollution Control Agency

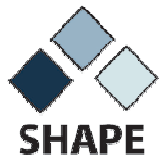

Community Leaders

Hennepin County - SHAPE Survey of the Health of All the Population and the Environment





- **Spray booth**
- **Emergency generator**
- **Maintenance activities**
- **Natural gas combustion for heating**



Health Endpoint	Acute (short term exposure)	Chronic (lifetime exposure)
Respiratory	screened in	
Developmental/Reproductive/Endocrine		
Hematological (e.g. blood, lymphatic and immune)		
Neurological		
Eyes (irritant)		
Alimentary (e.g. digestive)		
Bone & teeth		
Cardiovascular	screened in	
Kidney (e.g. renal)		
Hepatic (e.g. liver)		
Cancer		

These health endpoints were screened in for further analysis, this screening does not indicate a health impact



United States
Census

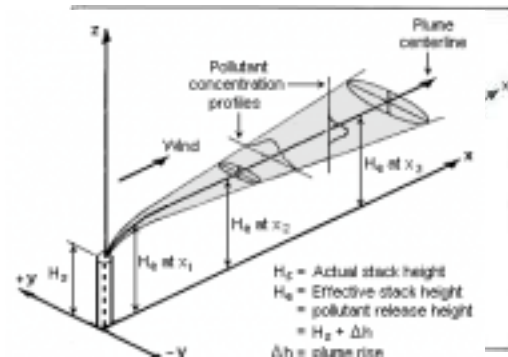
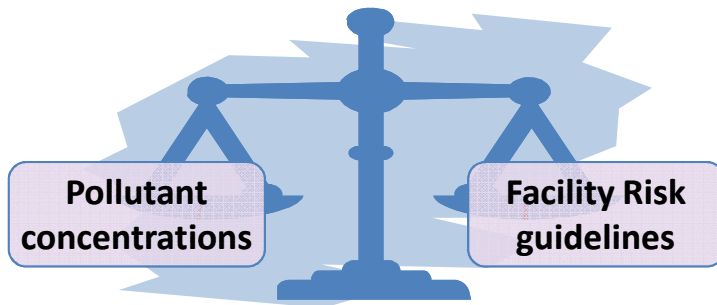

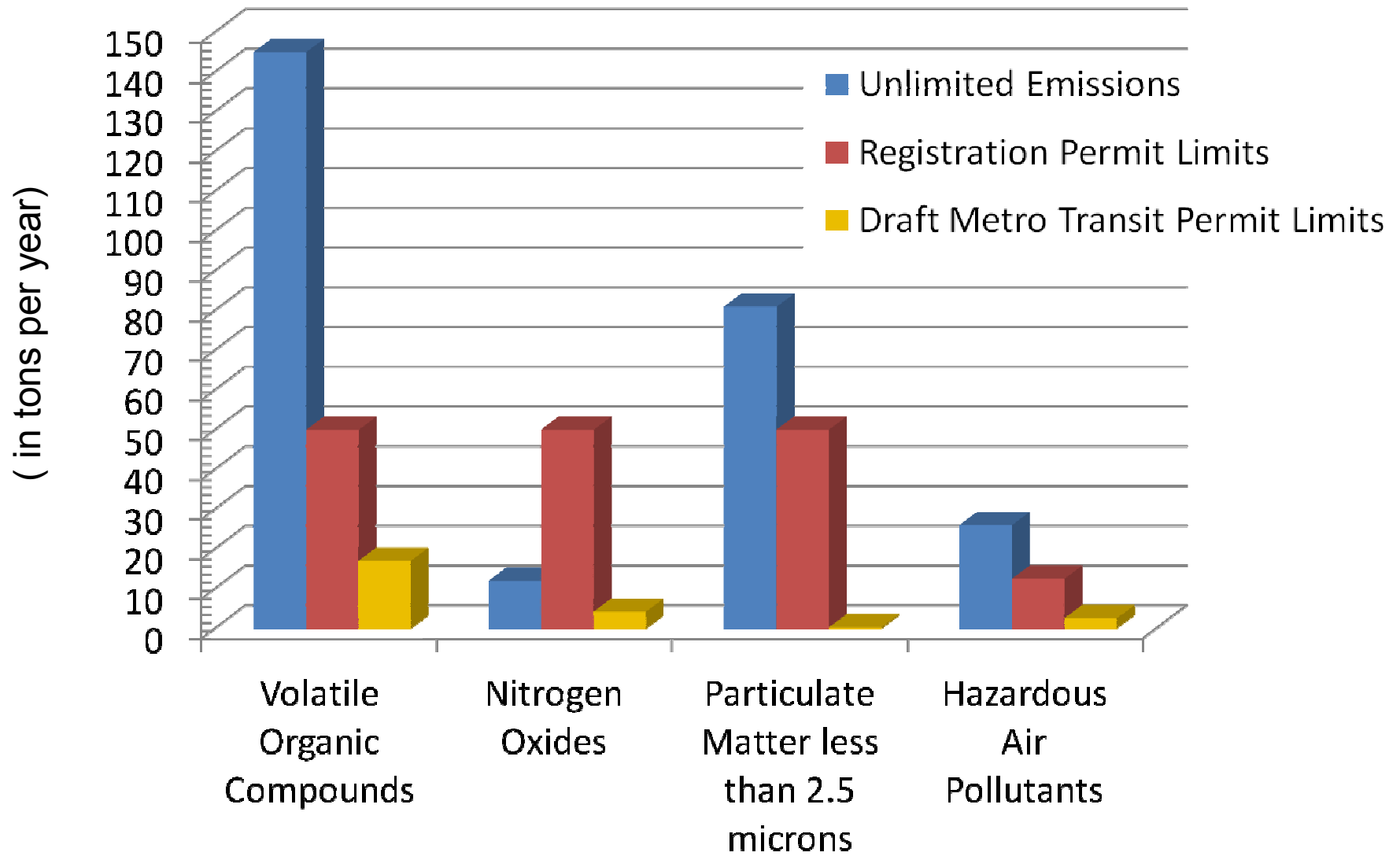

Getting the Word Out

Public Notice

StarTribune



Public
Informational
Meeting

<http://www.pca.state.mn.us/qzqh484>



News Releases



Information
sessions



What worked?

- Good available data and tools
- Cumulative Levels and Effects Process
- Technical check-ins

What makes this unique?

- Pre-selected area
- One facility at a time
- No cumulative benchmark
- Directed at MPCA – under permitting authority
- The word ‘consider

Cumulative Impacts in Permitting

Some Final Thoughts

Thank You

Sarah Sevcik

sarah.sevcik@state.mn.us

651-757-2715

<http://www.pca.state.mn.us/qzqh484>



**Minnesota Pollution
Control Agency**